

**This presentation can be navigated with buttons in the bottom right corner of the screen or with the "Page Up" and "Page Down" keys on the keyboard.**

**Each screen is accompanied by a note with further information.**

**Press the "ESC" key to escape the full screen presentation.**

**Click to begin the presentation.**



# Perforating Basics

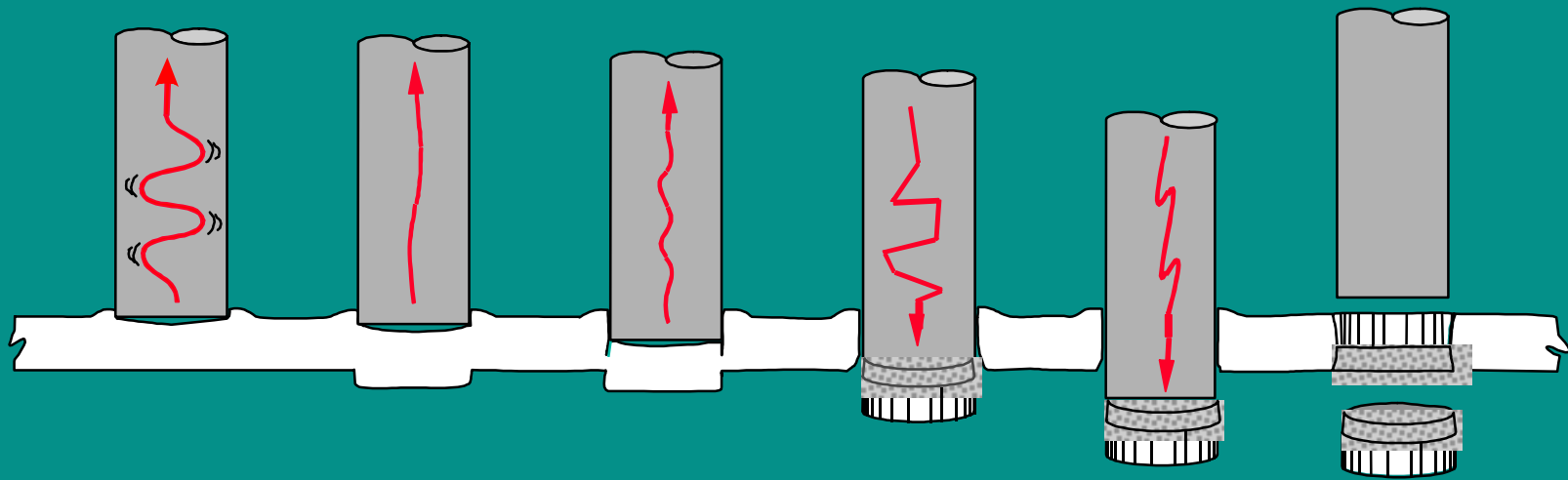

The Perforating Process





# Effect of Clearance

- ◆ Define Die Clearance
- ◆ Illustrate the Six Steps of the Perforating Process
- ◆ Explain the Advantages of using Engineered Die Clearance
- ◆ Simplify Maintenance of Ejector Type Punches





# Perforating

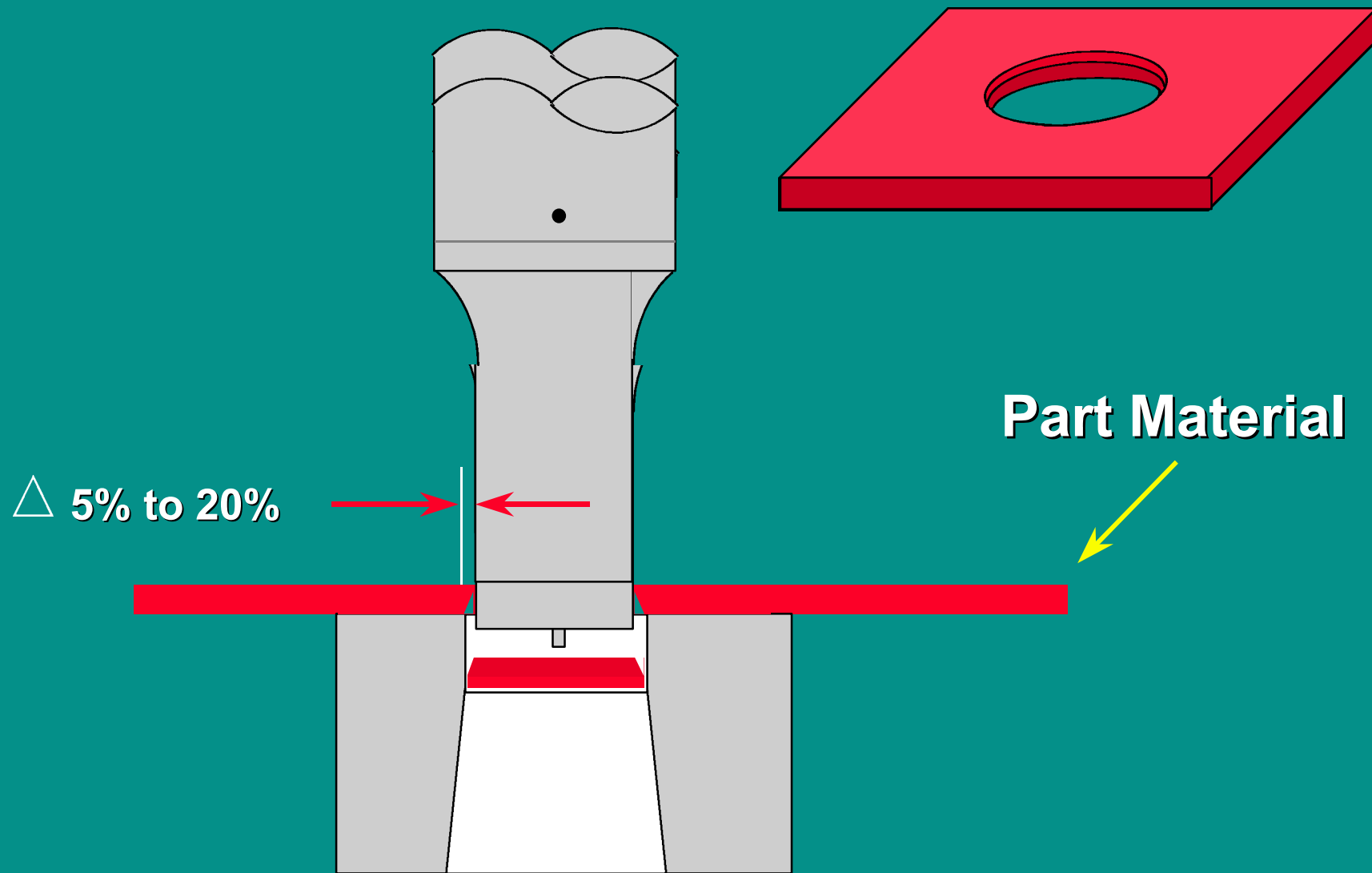

- Making a hole by removing a slug
- Hole size determined by punch point diameter





# Clearance

## Regular Clearance

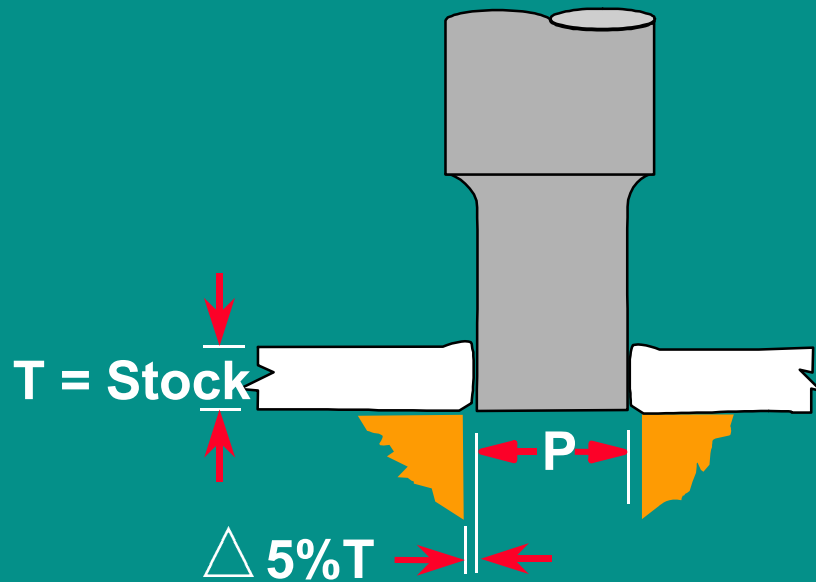

## Engineered Clearance

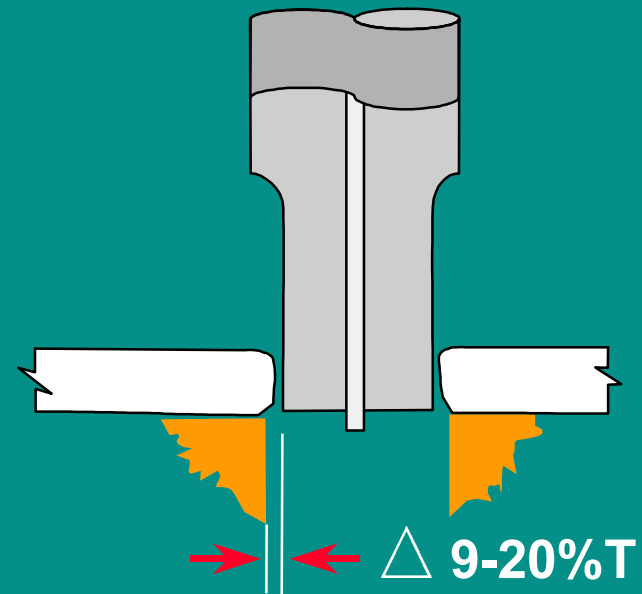

$\Delta$  = Clearance per side





# The Perforating Process

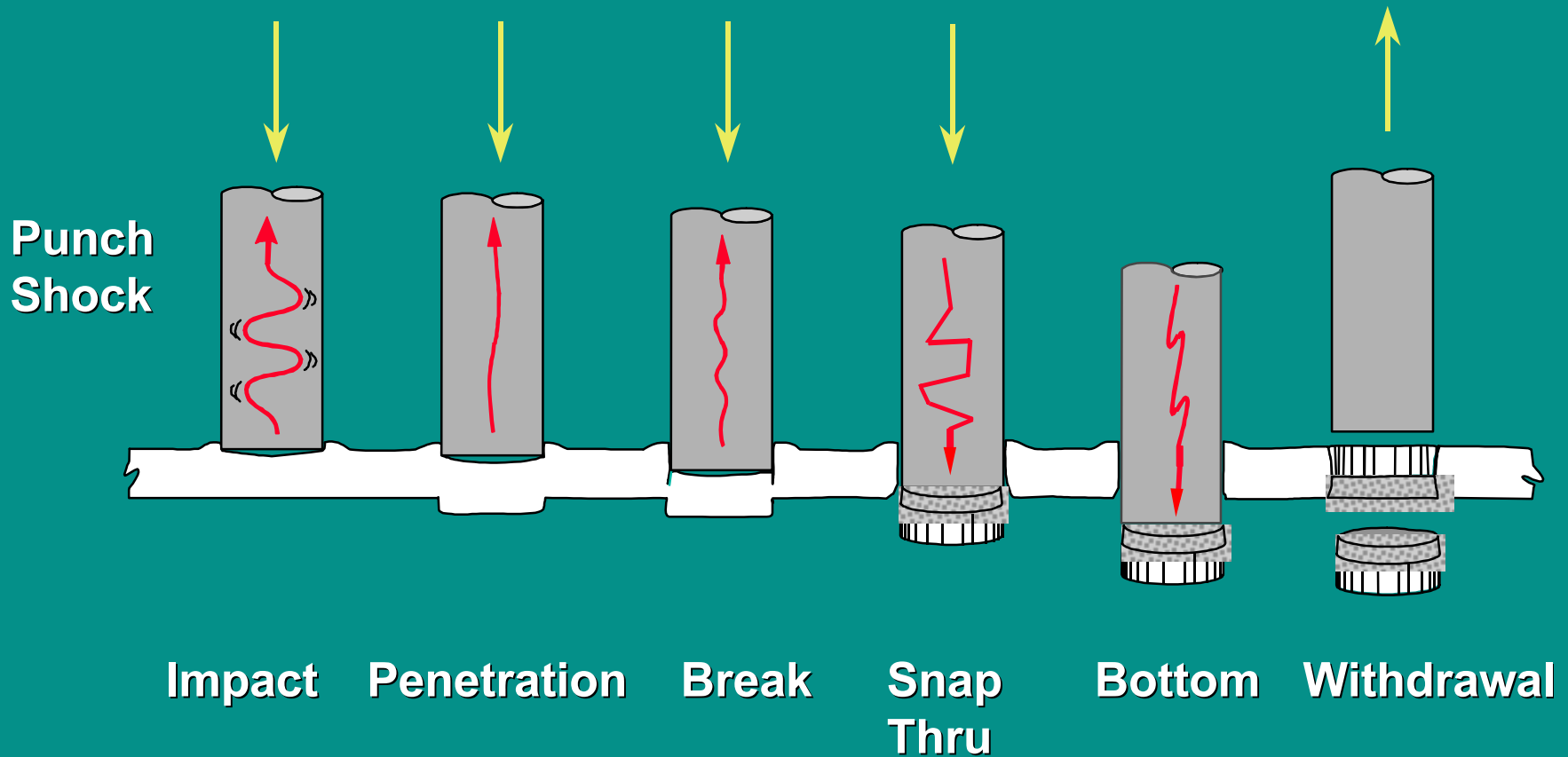

# Impact

## Regular Clearance

## Engineered Clearance

Direction  
of Punch

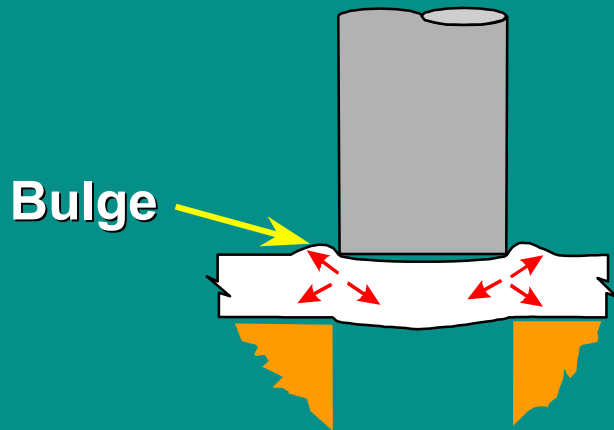

Increased  
Roll-Over

Reduced  
Bulge

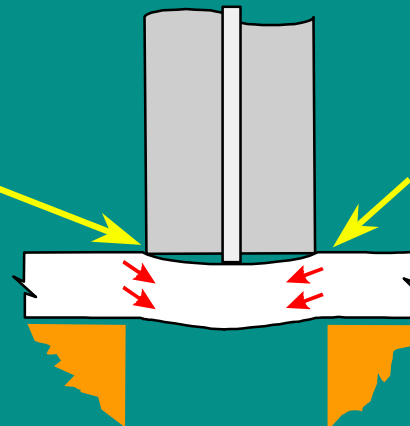

# Penetration

## How Clearance Effects Compressive & Tensile Stress

### Regular Clearance

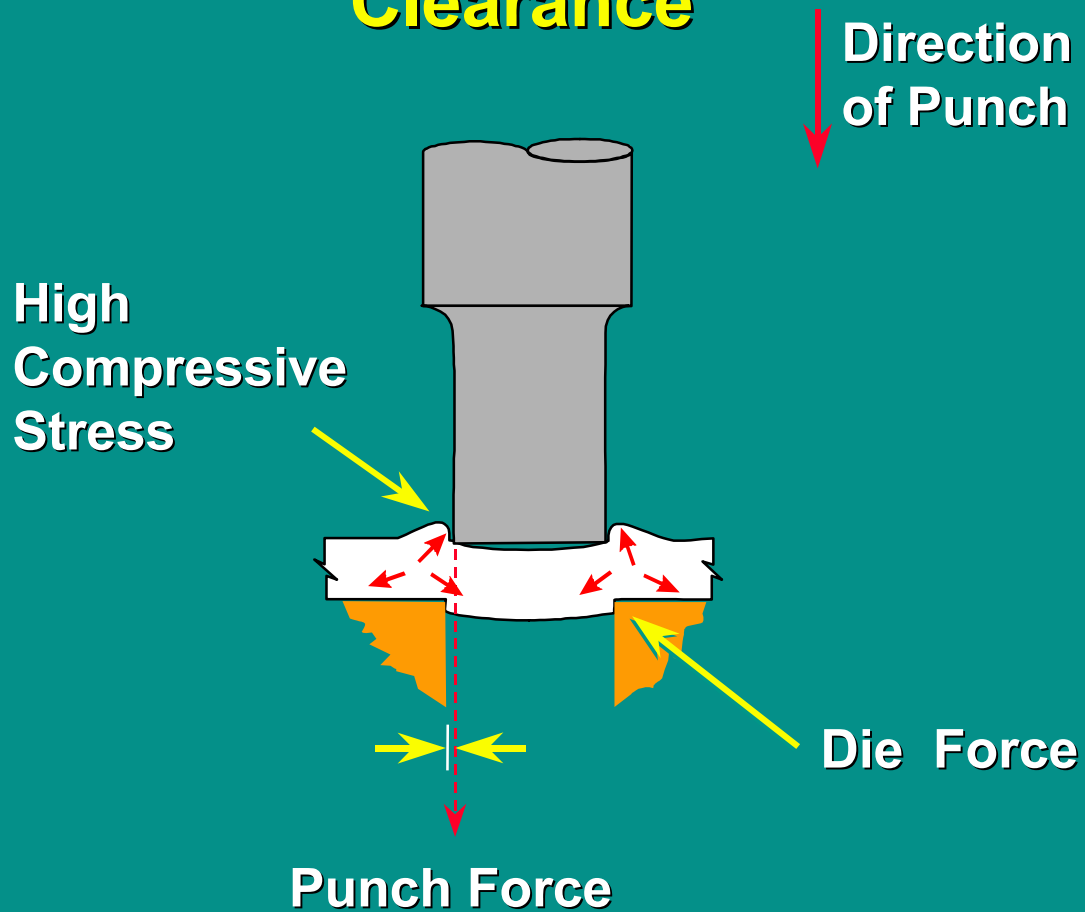

### Engineered Clearance

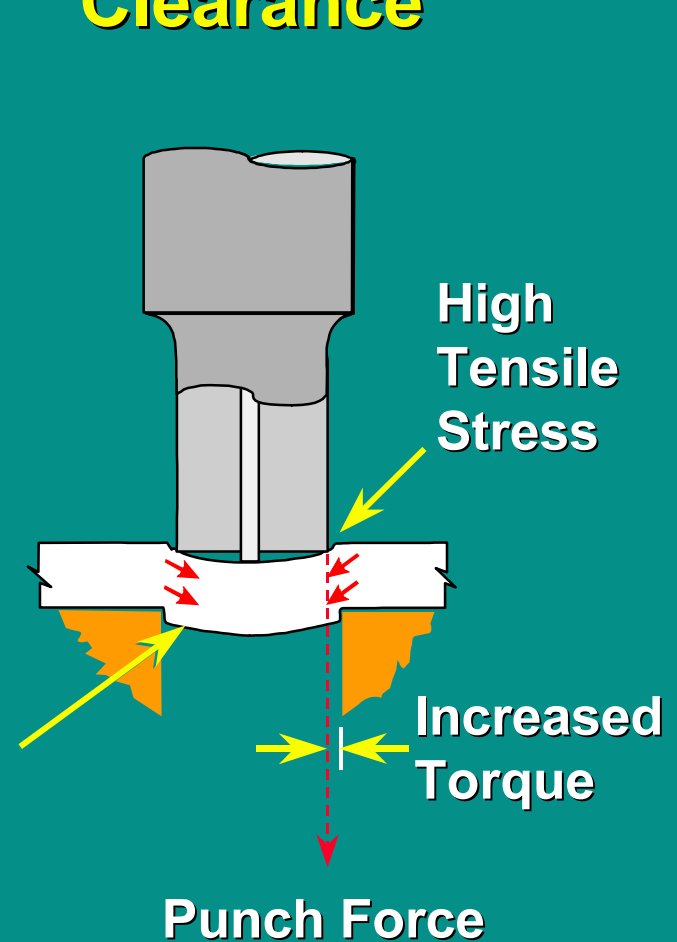

# Break

## Regular Clearance

## Engineered Clearance

Direction of Punch

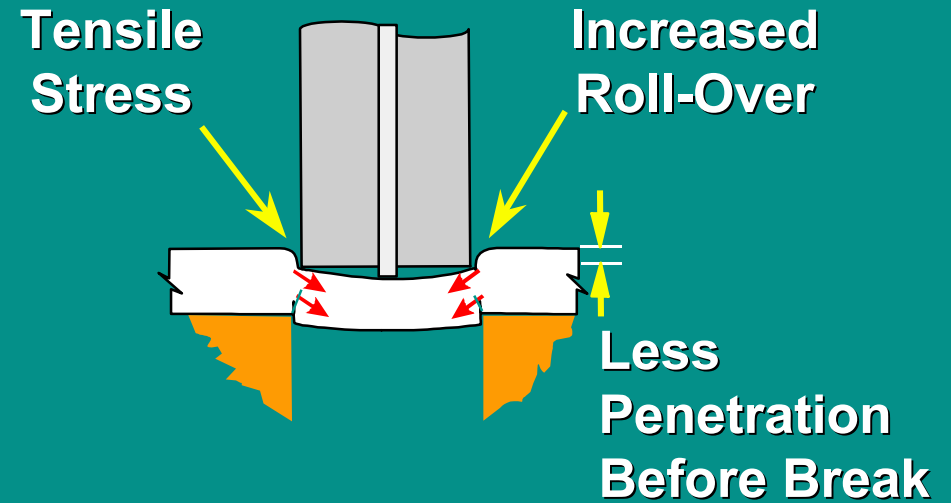
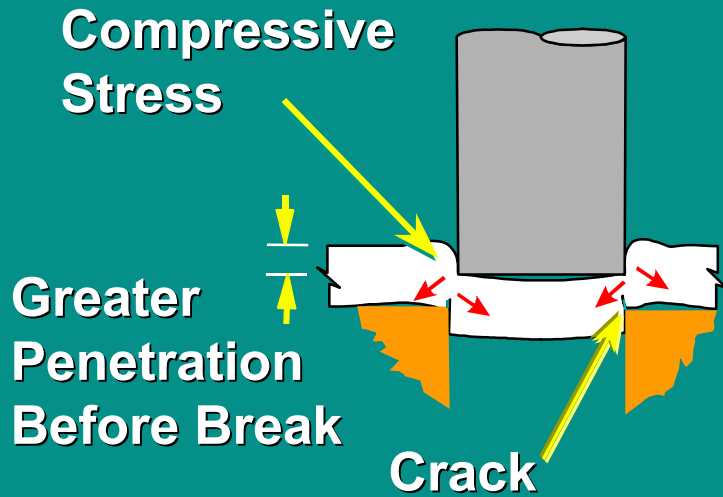

# Snap Thru

## Regular Clearance

## Engineered Clearance

Direction  
of Punch



Vacuum  
Pocket

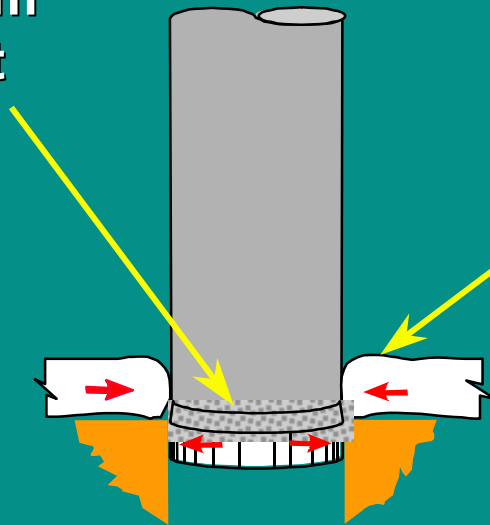

Reversal of  
Perforating  
Stress

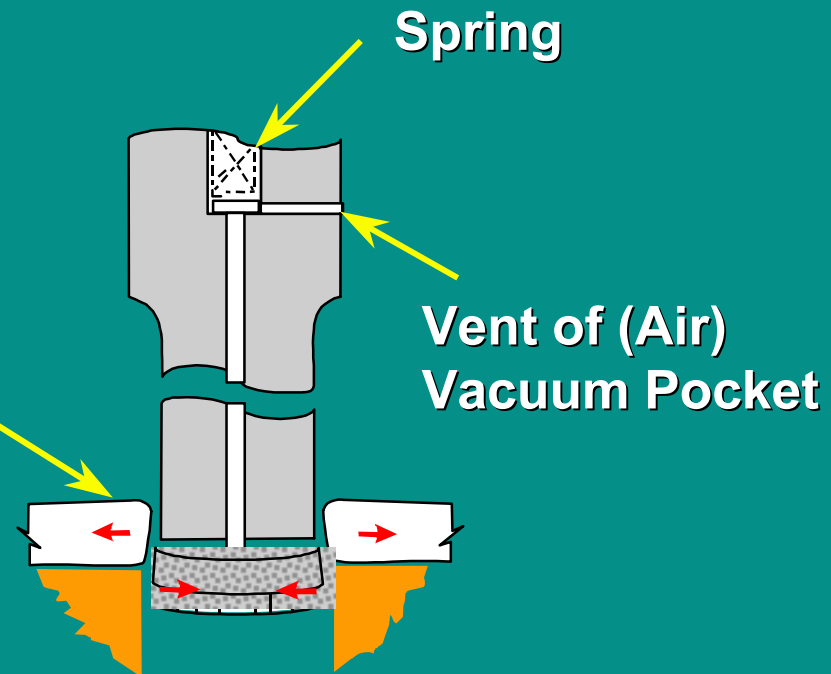

# Bottom

## Regular Clearance

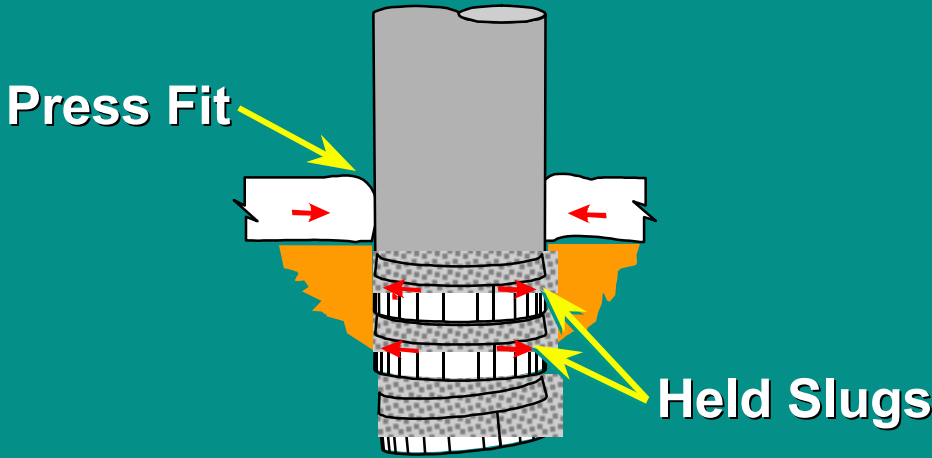

## Engineered Clearance

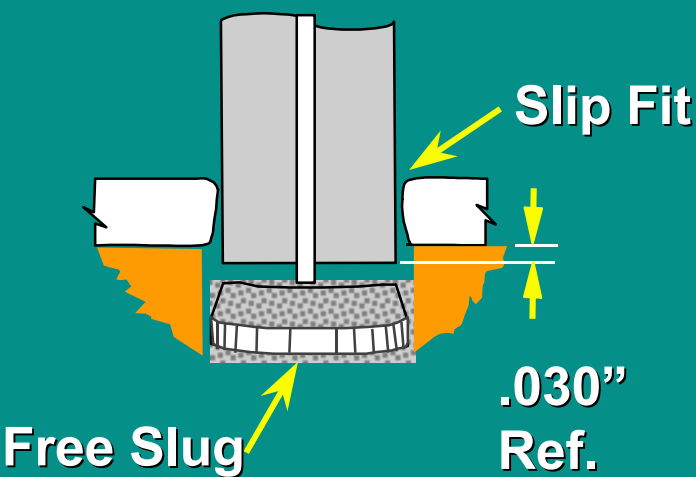

# Withdrawal

## Regular Clearance

## Engineered Clearance

↑  
Direction  
of Punch

.0001"-.002"

Press Fit  
(Excessive Wear)

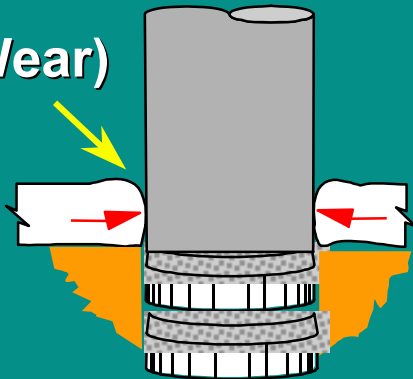

Stripping Force  
High

.0001"-.0015"

Slip Fit  
(Minimum Wear)

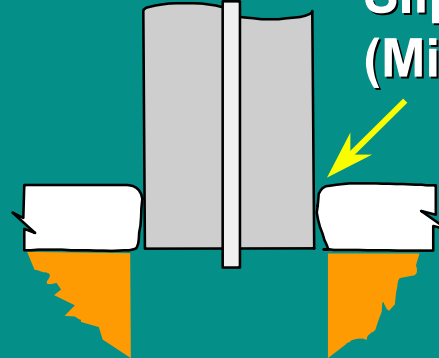

Stripping Force  
Negligible





# Tight Clearance



# Hole Characteristics

Regular  
Clearance

Engineered  
Clearance

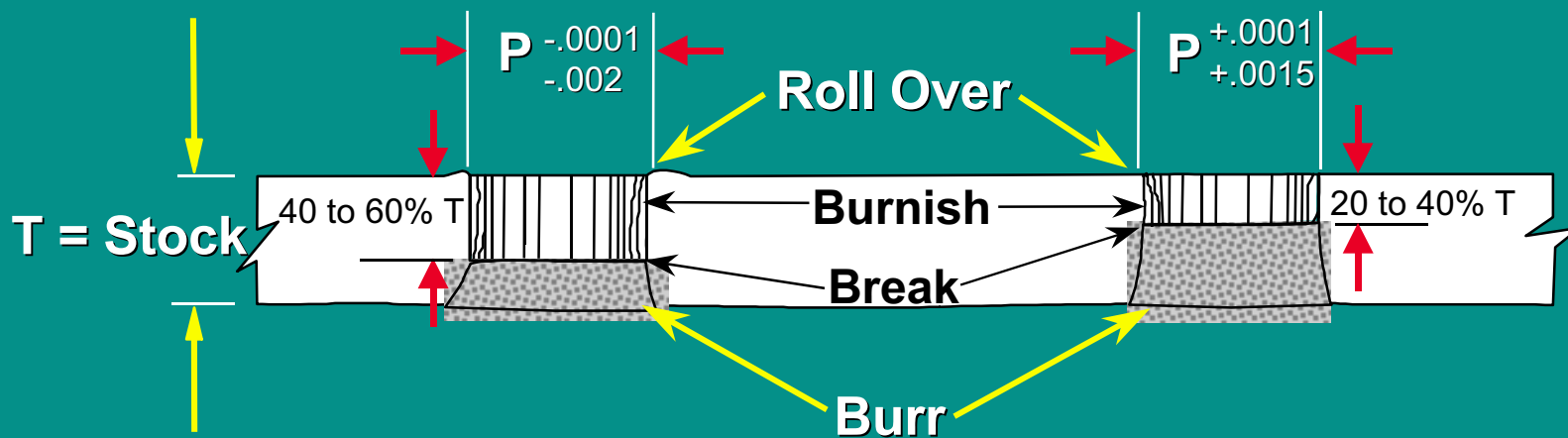

# Hole Size Comparison

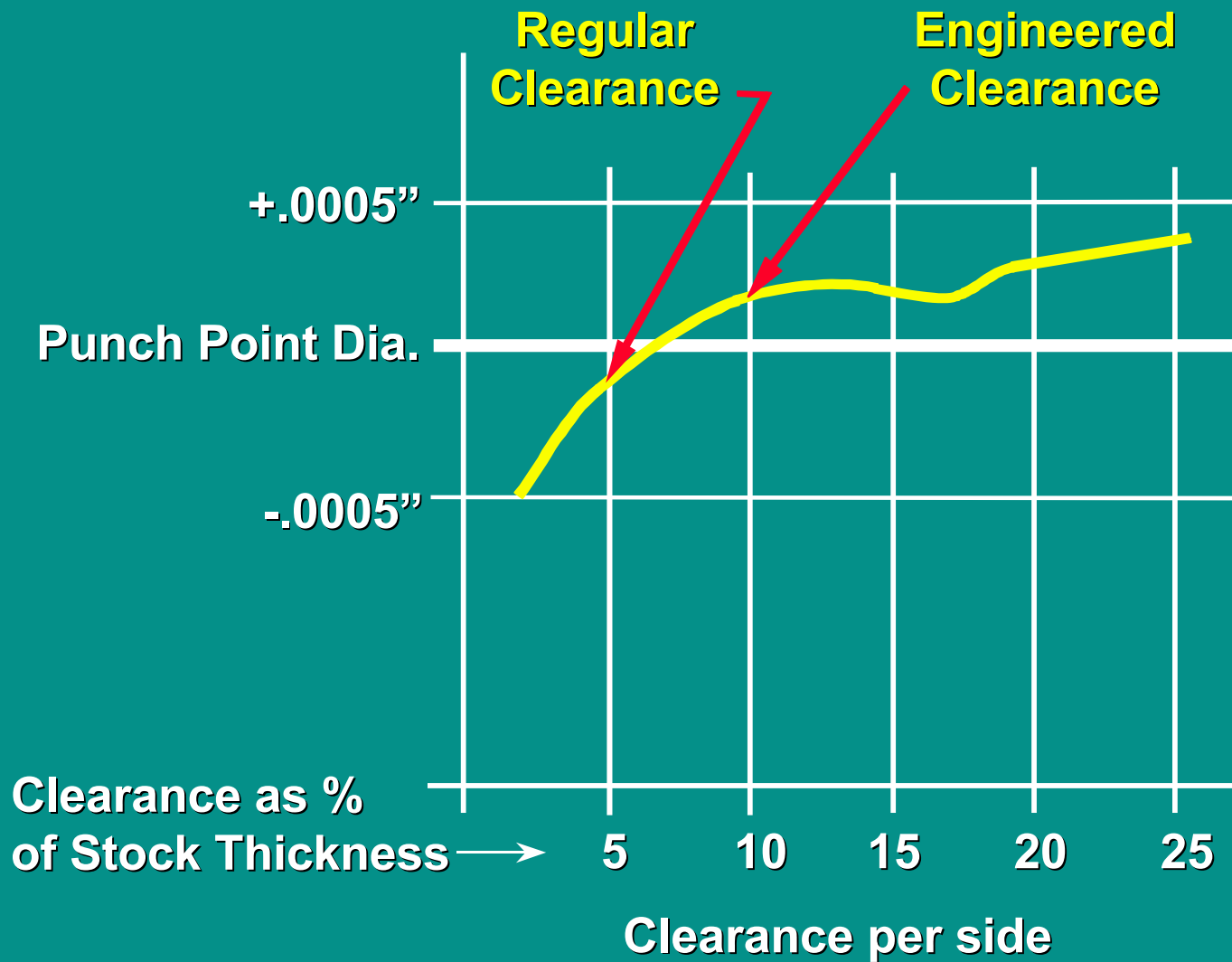

# Burr Generation

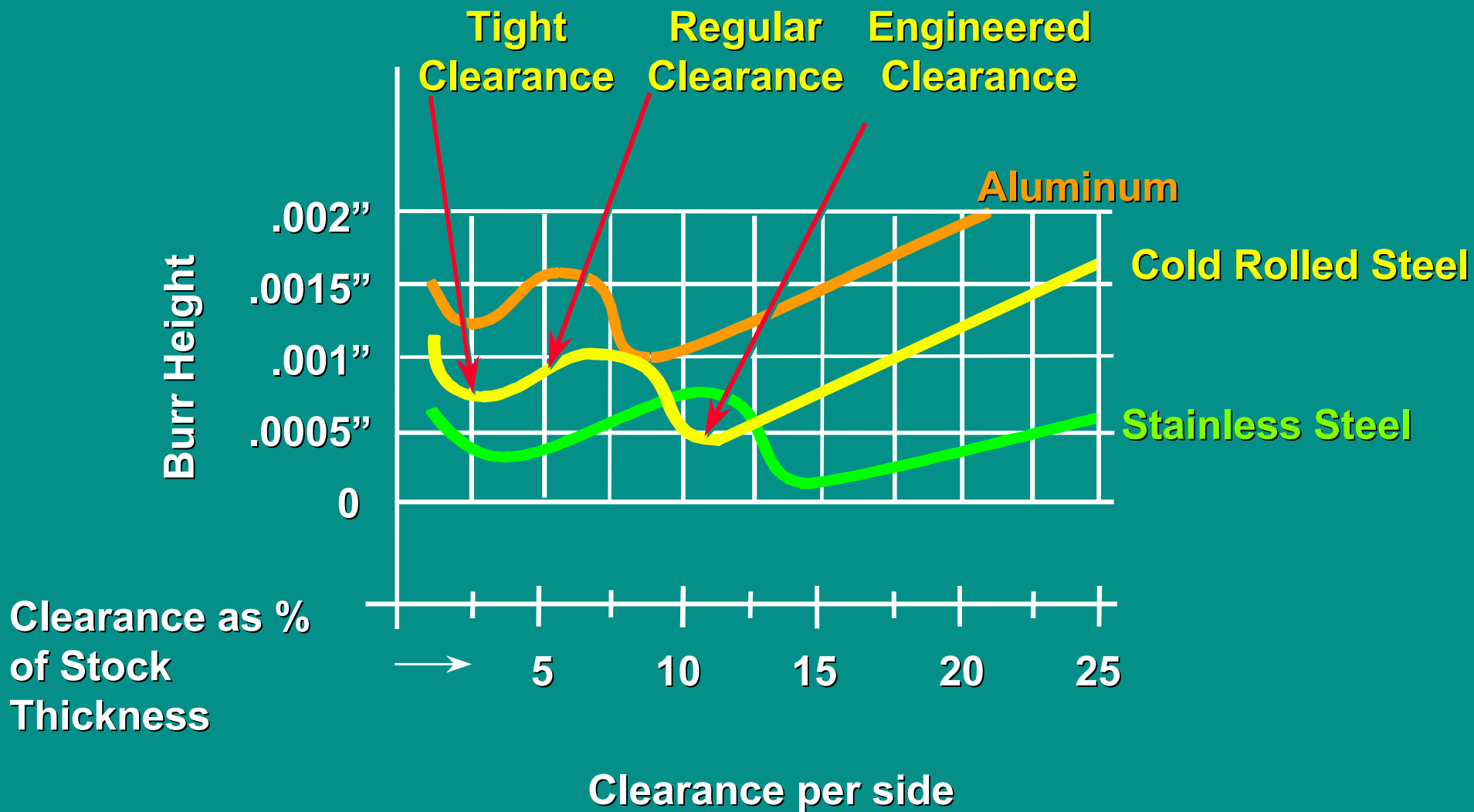

# Productivity

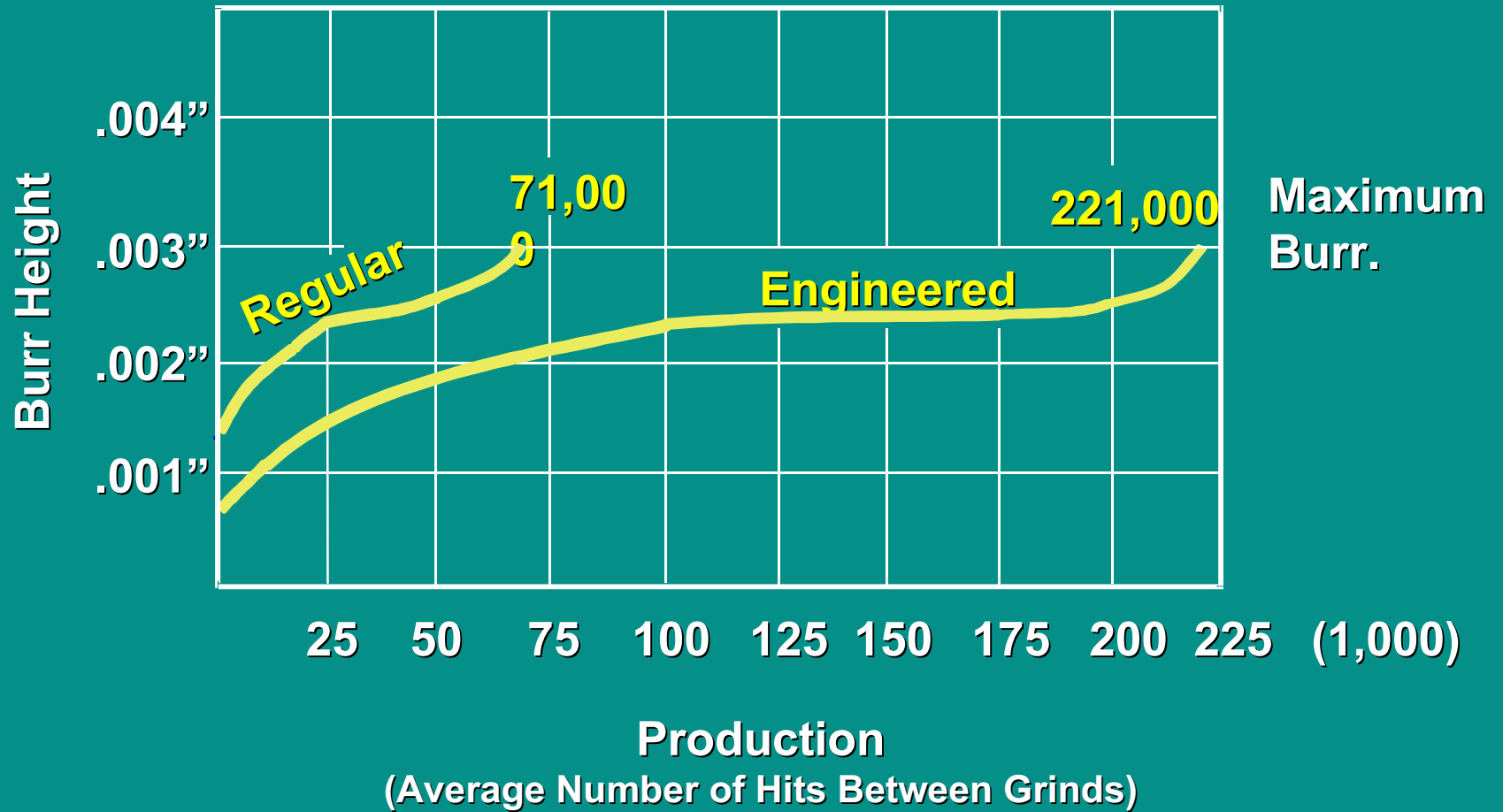

# Hole Size to Stock Thickness Association

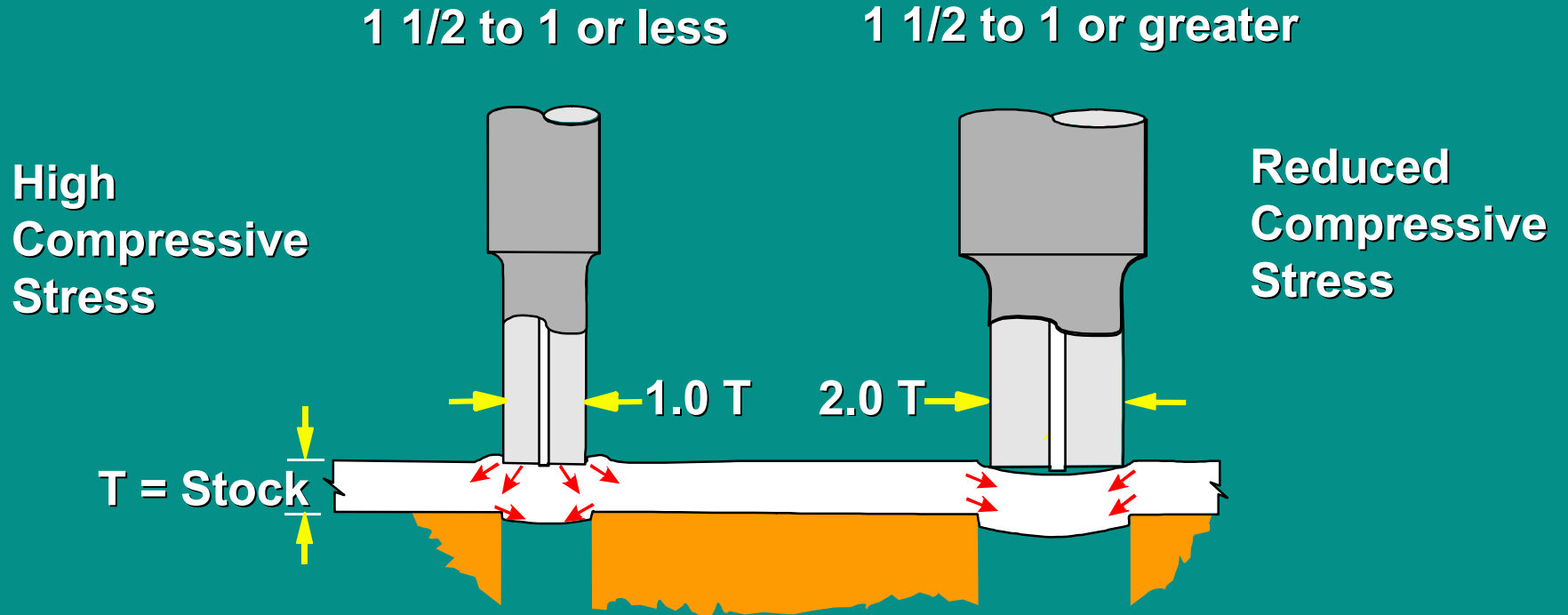

# Hole Size to Stock Thickness Association

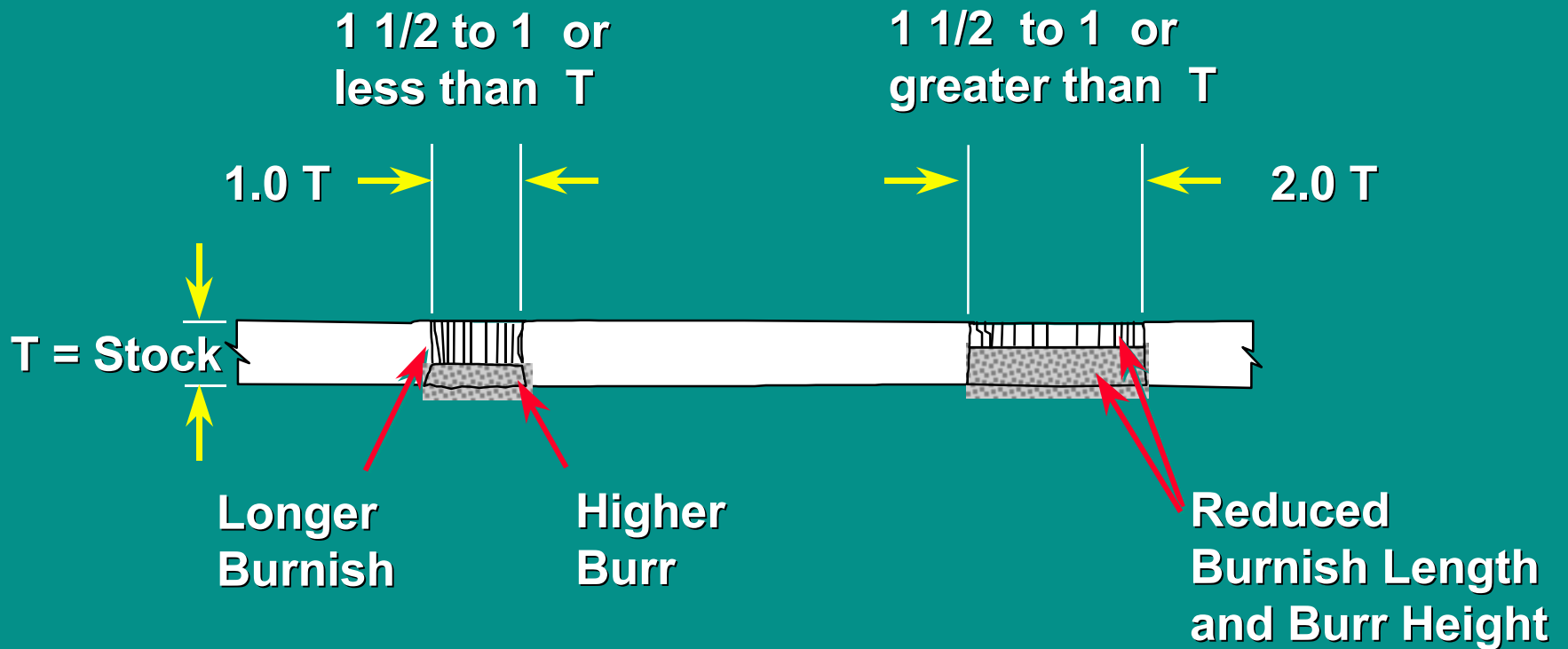

Hole Characteristics



# Point Chipping

Resharpener

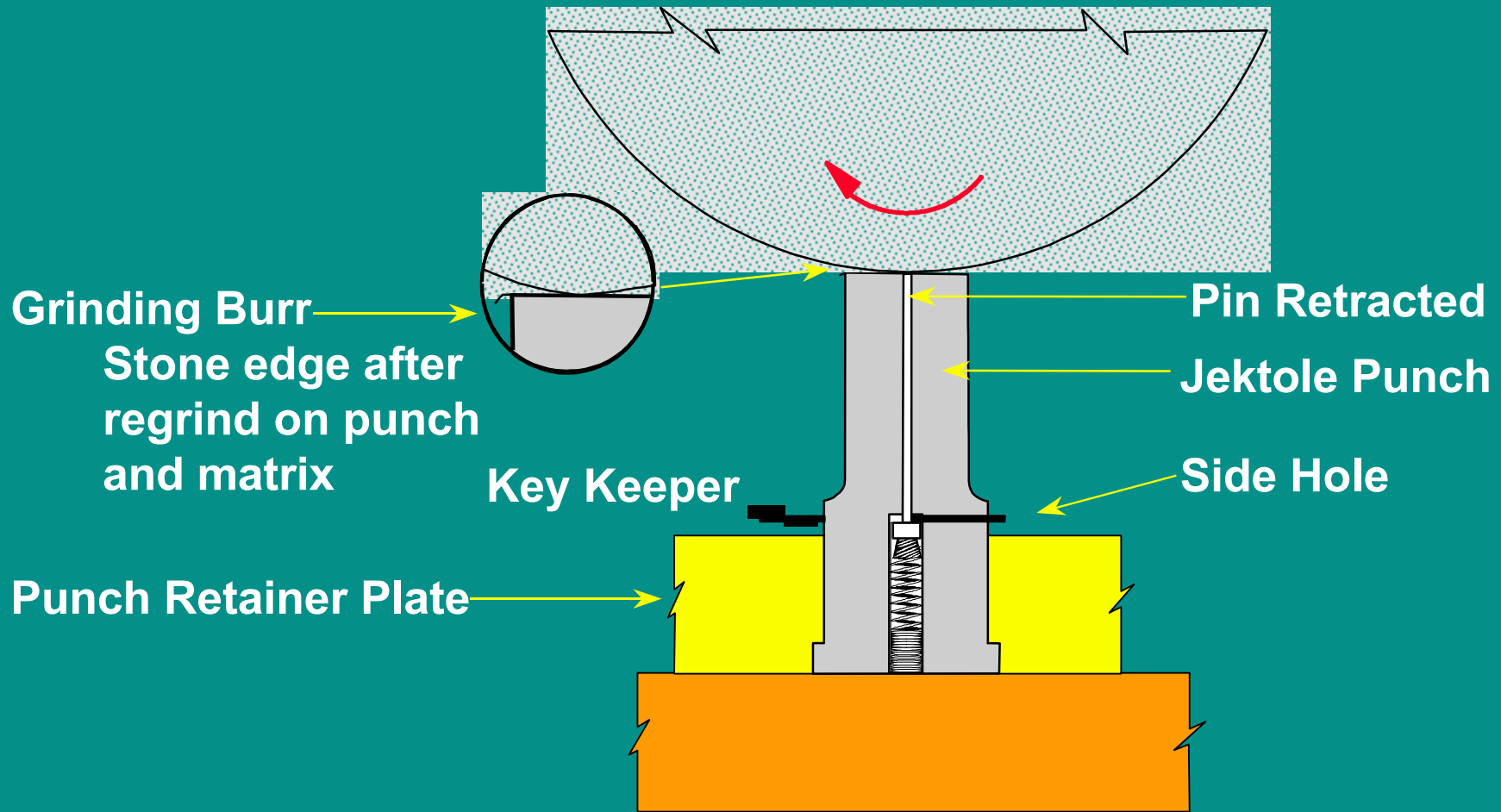

# Hole Diameter to Stock Thickness Ratio



# Clearance Testing

<i>Clearance Test Example</i>						
Hole #	1	2	3	4	5	6
% Thickness	3.2%	4.8%	6.4%	8.1%	9.7%	14.5%
Amount	0.001	0.0015	0.002	0.0025	0.003	0.0045
Hole Size	0.187	0.187	0.1874	0.1877	0.1879	0.1879
Burr Height	0.0058	0.0014	0.0013	0.0012	0.0007	0.0009

Holes produced by .1875 diameter punch.  
Clearance percent & amount given as per side.

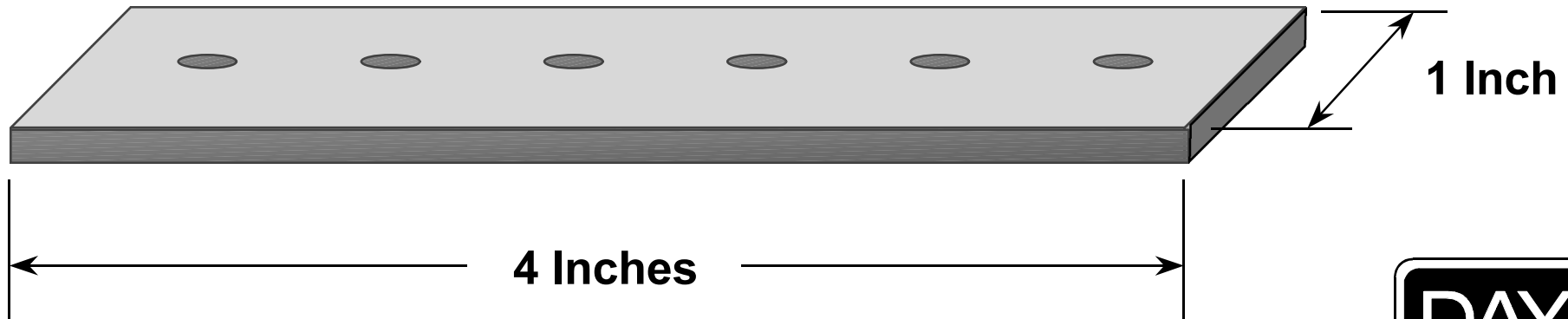

**An Exclusive Research Service by Dayton Progress Corporation**





## DAYTON PROGRESS CORPORATION

500 Progress Road • P.O. Box 39 • Dayton, Ohio 45449-0039

Telephone: (937) 859-5111 • Fax: (937) 859-5353

[www.daytonprogress.com](http://www.daytonprogress.com)

